

32" Vibrant Professional Advertising Displays



Cost-effective package solution; vibrant 24/7 commercial grade displays with built-in network Android 14 media player and 1 year CMS software subscription

700cd/m² Brightness

The 700 cd/m² brightness is around double that of most indoor commercial displays, ensuring your content grabs the attention of your audience and stands out clearly in brightly lit environments.

**700cd/m²
Brightness**



Complete Package Solution

We have combined a 24/7 commercial display, a network Android 14 media player, one year free CMS software and a library of pre-designed templates for the ultimate package solution.



**Save time
and Money**



24/7 Commercial Grade



Integrated Android 14
Media Player



25% Panel Haze



Integrated Speakers



700cd/m² Brightness



Remote Updates



Narrow Bezel



Exclusive Template Library



3-Year Commercial Warranty



Lifetime Technical Support

Other Features

Anti-Glare Panel With 25% Haze

With a 25% haze, the panel reduces reflections while maintaining image quality, ensuring critical information stays clearly visible. The anti-glare coating also boosts perceived contrast, delivering a sharper, more vibrant display.



Display with 0% Haze



Display with 25% Haze

1st Year Free Software Subscription

The first year of using our cloud based CMS is absolutely free. You can also purchase 3 additional year's access at the point of purchase or make a one off payment to have access for life.



24/7 Commercial Use

Designed for 24/7 use, these displays feature a commercial grade direct lit LCD panel with an LED backlight rated for over 70,000 hours. They offer consistent brightness and vibrant colour with reduced degradation over time, making them a more sustainable long term solution.



Built-In Speakers

Take your digital signage solution to the next level by adding an audio element using the two integrated slimline speakers.



Instant Remote Updates

My Signage Portal gives you complete control over your digital displays from anywhere in the world. Schedule content, manage multiple screens, and make instant updates remotely—all through one easy-to-use online platform.

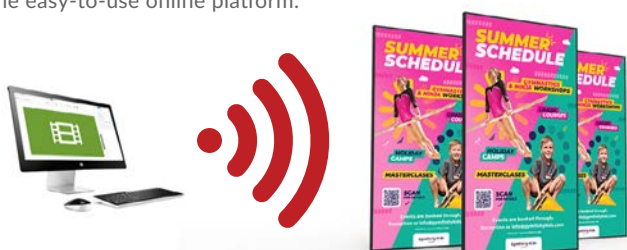

Integrated Android 14 Media Player

The integrated Android 14 media player allows for easy updates via the internet and My Signage Portal. With a 25% performance boost compared to previous versions, the Android 14 OS also ensures full compatibility with modern applications and software.



Budget Friendly Window Display

For installations with a tighter budget, this screen can be used as a budget-friendly yet highly effective window display. At 700cd/m², it is brighter than other commercial displays but without the price tag of an ultra-bright display.



Equal Narrow Bezel

The slim, even bezel on all sides of the Vibrant Professional Advertising Displays keeps focus on your content — ideal for clean, seamless alignment when placing multiple screens side by side.



Key Features

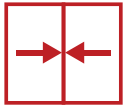

EQUAL NARROW BEZEL



INTEGRATED ANDROID 14 MEDIA PLAYER



700CD/M² DIRECT-LIT PANEL



24/7 COMMERCIAL GRADE



FULL HD DISPLAY



INTEGRATED SPEAKERS



25% PANEL HAZE



BUILT IN WIFI



mySignage portal

CONTENT MANAGEMENT SOFTWARE

1 YEAR FREE

ONE YEAR FREE SOFTWARE SUBSCRIPTION

INTEGRATED SPEAKERS

700CD/M² BRIGHTNESS

Android 14

INTEGRATED NETWORK ANDROID 14 MEDIA PLAYER

Specification Table

V.1.0	DM32HD10	
Display	Resolution	1920 x 1080 @60Hz
	Display/Active Area [mm]	702.6 x 397.1
	Aspect Ratio	16:9
	Brightness [cd/m ²]	700
	Colour	16.7M (8bit); 72% NTSC
	Haze Level	25%
	Viewing Angle [°]	89/89/89/89
	Contrast Ratio	1,200: 1
	Orientation Support	Landscape / Portrait
	Operating Hours	24/7 Commercial Use
System & Performance	CPU	RK3568 64bit Cortex-A55 Quad @2GHz
	GPU	Quad Mali-G52 2EE
	Graphics API Support	OpenGL ES 1.1/2.0/3.2, OpenCL 2.0 and Vulkan 1.1
	OS Operating System	Android 14
	RAM	4GB
	Storage	32GB
	Media Format	Supports FHD 60FPS H.264/H.265 video encoding
	LAN	10/100/1000M RJ45
	Wi-Fi	Dual-band 2.4GHz / 5GHz (802.11a/b/g/n/ac)
	Bluetooth	5.0
Optional 4G Module	1 x SIM Slot (optional)	
Connectivity & Interface	HDMI	1 x HDMI 2.0 IN
	USB	1 x USB 3.0 Type-A; 1 x USB 2.0 Type-A; 1 x USB Type-C (OTG only)
	RS232	1 x RJ45 (Serial Control)
	Ethernet	1 x RJ45 (10/100/1000M)
	Audio Out	1 x 3.5mm Audio Out
	Expansion Slot	1 x Micro SD
	Power Input	1 x IEC C6 (Cloverleaf)
	Switch	1 x Power Switch
	Speakers	2W x 2
	4G Module (Optional)	1 x SIM In
Power Management	Power Supply	AC 100-240V, 50/60Hz
	Power Consumption	Typical: 50W; Max: 55W
	Standby Power	≤0.5W
Dimensions & Weight	Screen Dimensions (mm)	718.2 x 412.7 x 59.1
	Package Dimensions (mm)	817 x 512 x 116
	VESA Mounting (mm)	400 x 200 M6 12mm
	Net Weight	5.73 kg
	Gross Weight	7.98 kg
Environmental Conditions	Operating Temperature [°C]	0 to 40°C
	Storage Temperature [°C]	-10°C to 55°C
	Operating Relative-Humidity [%]	10% to 80%
	Storage Relative-Humidity	10% to 80%
Accessories	Included Accessories	Cloverleaf Power Lead (1.8m); Remote Control + Batteries; User Manual (QR Code x2); Quick Start Guide
	Optional Accessories	Wall Mount, Floor Stand/Trolley, Ceiling Mount, Table Stand
Warranty	Warranty Period	3 Years
	Technical Support	Lifetime



Errors and omissions excepted

Technical Drawing

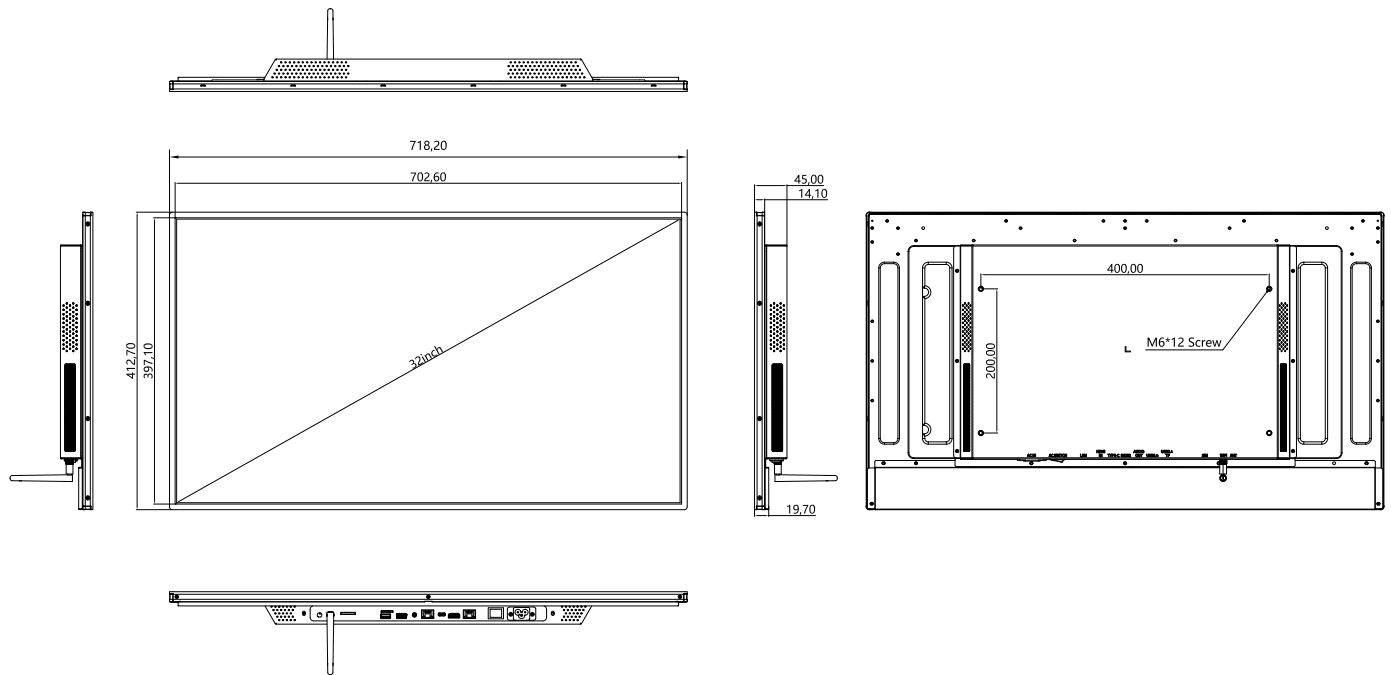

Why Choose Our Commercial Display Solutions?



Lifetime Technical Support

From the moment you receive your product, throughout the duration of your warranty and even after your warranty has expired we are here to support you. If you require any assistance setting up or using your product, or have any problems at all, we can provide free technical support via telephone and email.

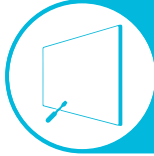

On-site Support and Maintenance*

If needed, we can provide an installation service for any of our products. We can also set up service-level agreements for larger projects that require maintenance contracts.



Extended Warranty*

All of our commercial display products come with a 3 year commercial warranty as standard but if you want to extend this you can upgrade this to cover a 5 year period at point of purchase.



Training

As well as providing free remote CMS training sessions and webinars we can also visit you to deliver bespoke training for our software and hardware*.



Advanced Replacements†

Should your display suffer from any kind of hardware failure during the warranty period we will send you an advanced replacement and arrange for your old display to be collected, free of charge. This ensures no downtime where you are without a screen.



Custom Product Testing & Configuration

If you need us to test third party software or a website, or configure your screen in a particular way before it is dispatched (e.g. in a particular orientation or network mode), we can do so to make your life easier.



3D Rendering

Want to know how a particular screen will look once installed? Send us a photo of the location and we will create a 3D rendering of any screen in situ to help you to visualise how amazing it will look.



Logistics Support

We hold more stock in our UK warehouse than any other manufacturer so we can help you meet tight deadlines. For last minute orders we can also offer special express or morning delivery options*. We also carry out UK based quality control checks on every display before it leaves our warehouse.



Project Support

If you need to loan a sample unit to test we'd be more than happy to arrange this. We can also provide a rental service for temporary projects*.



Customisation*

Your display can be customised to suit your requirements by adding your logo or printed graphics or even tailoring the colour of a display. We can also carry out hardware modifications to existing products or manufacture bespoke solutions for special projects.



Extras*

As well as being able to provide accessories and add-ons, such as extra remote controls, NUC PCs and video wall controllers, we can also supply custom made flight cases which are great if a display needs to be moved safely from place to place.

†UK mainland only

*These particular services may incur additional charges